

# WORKMATE™ ELECTRIC CHAIN HOISTS AND TROLLEYS

**SPANCO®**  
Promise to Perform Industries, Inc.

## THE PERFECT PARTNER FOR YOUR CRANE



**WARNING**

Failure to follow these warnings may result in death, severe injury or property damage:

- Do not exceed the rated capacity of the hoist. See the instruction manual for more information.
- Do not lift people or loads over people.
- Do not lift loads from tilted loads.
- Do not use hoists unless used in a safe manner.
- Do not operate with hoists, unless the hoist is in a safe condition.
- Do not operate if damaged or malfunctioning hoist.
- Do not remove or obscure warning labels.

Spanco.com  
1 ton

# WORKMATE™ ELECTRIC CHAIN HOISTS

Quality and reliability are at the heart of our Workmate™ Electric Chain Hoists. The Workmate is built with a modern design that allows for a lightweight frame and sacrifices no capacity to do so. The ability to handle industrial grade applications alongside the Workmate's durable components make it a superior product to other chain hoists in its weight class.

## FEATURED OFFERING

- Electric Chain Hoists can be paired with Spanco Gantry, Workstation, and Jib Cranes
- Available with capacities of 1/4-Ton, 1/2-Ton, 1-Ton, 2-Ton, 3-Ton, 4-Ton, and 5-Ton
- Standard lift heights from 10' - 20' in one-foot increments
- Available voltages are 110V, 230V, and 460V
- 42V controls



Jib Crane



Gantry Crane



Freestanding Workstation

Base Model	Capacity (Tons)	Phase	Voltage	Speed	Speed (ft/min) 60Hz	Falls
<b>SINGLE PHASE OFFERING</b>						
SP250	1/4-Ton	Single	110V/60Hz 230V/60Hz	Single	16 FPM	1
SP500	1/2-Ton	Single	110V/60Hz 230V/60Hz	Single	16 FPM	1
	1-Ton	Single	110V/60Hz 230V/60Hz	Single	8 FPM	2
<b>3-PHASE OFFERING</b>						
SP250	1/4-Ton	Three	230V/60Hz 460V/60Hz	Dual	32/8 FPM	1
SP500	1/2-Ton	Three	230V/60Hz 460V/60Hz	Dual	32/8 FPM	1
	1-Ton	Three	230V/60Hz 460V/60Hz	Dual	16/4 FPM	2
SP1000	1-Ton	Three	230V/60Hz 460V/60Hz	Dual	32/8 FPM	1
	2-Ton	Three	230V/60Hz 460V/60Hz	Dual	16/4 FPM	2
SP2000	2-Ton	Three	230V/60Hz 460V/60Hz	Dual	32/8 FPM	1
	3-Ton	Three	230V/60Hz 460V/60Hz	Dual	16/4	2
	4-Ton	Three	230V/60Hz 460V/60Hz	Dual	16/4	2
SP2500	3-Ton	Three	230V/60Hz 460V/60Hz	Dual	25.2/6.3	1
	5-Ton	Three	230V/60Hz 460V/60Hz	Dual	16/4	2

Duty Rating HMI – H4 for all models

# PRODUCT FEATURES

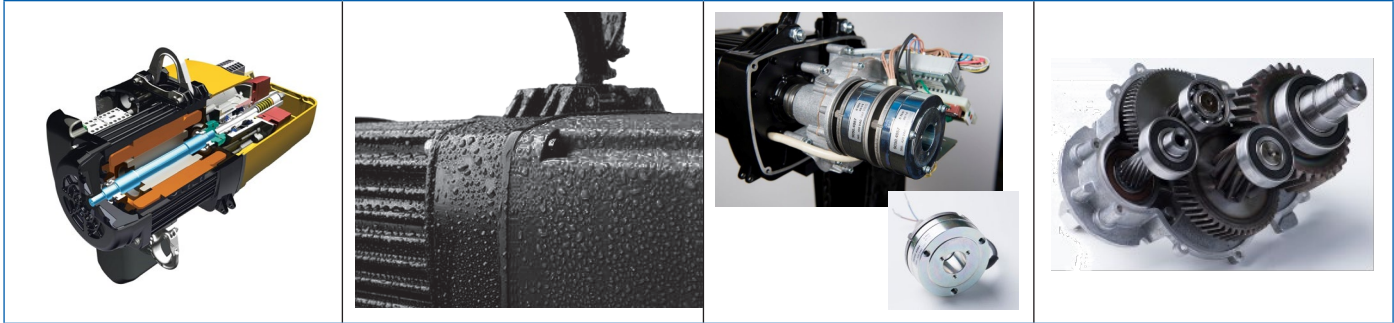

## MOTOR

Duty cycle rating of H4. External motor with cooling fins and fan wheel has 30% reduction in operating temperature (140°F).

Keyless shaft-to-pocket wheel connection, built to a self-centering polygonal design. Faster to reassemble, less strain on shaft.

5-pocket wheel is standard.



## INDUSTRY IP65 PROTECTION

Built for all environments. The hoist bodies are dust tight, water jet resistant, and have built in housing drains, while the chains have a corrosion resistant coating.

## DC-SPRING-LOADED BRAKE

- Requires rectifier AC to DC
- Brake releases when energized
- Maintenance-free and highly reliable
- Single-disc brake with two friction surfaces

## CLOSED GEARBOX

Modular, self-enclosed and permanently lubricated gearbox eliminates mess during disassembly.

## EYEBOLT SUSPENSION

- Made of aluminum die cast
- Hinged by loosening one screw making it easier to install



## CHAIN

The case hardened and manganese phosphate profile steel chain provides about 15 % more capacity at an identical nominal diameter when compared to the traditional round steel chain.

With 15% increased lifting capacity at the same chain diameter, the chain is 20-60% lighter than major competitors in its class.

The larger cross-sectional area reduces wear and increases the lifetime of the chain. The load hook with stable, guided hook latch and safety rubber buffer provides maximum safety.

Salt Spray Test before and after:

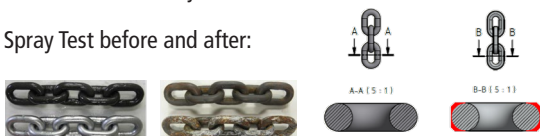

## TWIST LOCK KITS\*

Model	Phase/Voltage
<b>TWIST LOCK KIT OFFERING</b>	
TL-1P125V-K	1P/125V
TL-1P250V-K	1P/250V
TL-3P250V-K	3P/250V
TL-3P480V-K	3P/480V

\*Include male and female plug

# WORKMATE™ MANUAL TROLLEYS

Workmate™ manual trolleys are simple in design and allow smooth transportation of loads up to 5 tons on steel beams. Both the fall intervention protection components and the integrated fall and climbing protection are made of solid cast steel for maximum safety. Our Workmate manual trolleys have good and easy handling, which makes for a perfect fit with any underslung travelling crane.

## FEATURED OFFERING

- Manual trolleys can be paired with our line of Workmate electric chain hoists
- Available with capacities of 1/2-Ton, 1-Ton, 2-Ton, 3-Ton, 4-Ton and 5-Ton
- Adjustable flange widths of 2-3/4" through 11-13/16"
- Come standard with crown wheels. Can be used with S-Beams & W-Beams.

Model	Capacity (Tons)	Weight	Flange Width Range (in)	Number of Support Bolts
<b>MANUAL TROLLEY OFFERING</b>				
GHF500K	1/2 Ton	5.5 lbs	3-15/16" - 5-7/8"	1
GHF1250-S	1 Ton	24.3 lbs	2-3/4" - 7-7/8"	1
GHF1250-L	1 Ton	24.3 lbs	2-3/4" - 9-7/16"	1
GHF2500-S	2 Ton	44.1 lbs	3-7/16" - 7-7/8"	1
GHF2500-L	2 Ton	44.1 lbs	3-7/16" - 11-13/16"	1
GHF5000	3, 4, 5 Ton	70.6 lbs	3-9/16" - 11-13/16"	2

Visit Spanco's online configurator to verify hoist/trolley compatibility

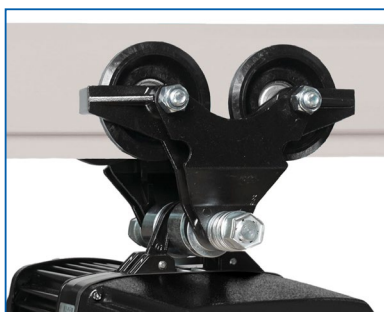

GHF500K





## MANUAL TROLLEY BENEFITS

Workmate manual trolleys are designed for maximum flexibility and longevity. The trolley can be customized to your specific beam size because of the intuitive and innovative engineering on the trolley body and multiple available wheel sizes. This can help ensure a longer service life and optimum running properties. The flange width is customizable and can be granularly adjusted to fit your system and then easily locked into place.



# WORKMATE™ MOTORIZED TROLLEYS

Workmate motorized trolleys pair with our line of electric chain hoists to move up to 5 tons smoothly and quietly. The travel movement is matched to the load and the local conditions, with fixed travel speeds or infinitely variable by means of a frequency inverter.

## FEATURED OFFERING

- Available with capacities of 1-Ton, 2-Ton, 3-Ton, 4-Ton, and 5-Ton
- Adjustable flange widths of 2-3/4" through 11-13/16"
- 4, 6, and 8-button pendants available in both wired and remote applications

Model	Capacity (Tons)	Weight	Flange Width Range (in)	Number of Support Bolts
<b>MOTORIZED TROLLEY OFFERING</b>				
GMF1250/NF-S	1 Ton	66.1 lbs	2-3/4" - 5-1/2"	1
GMF1250/NF-L	1 Ton	66.1 lbs	2-3/4" - 9-7/16"	1
GMF2500/NF-S	2 Ton	83.7 lbs	3-7/16" - 7-7/8"	1
GMF2500/NF-L	2 Ton	83.7 lbs	3-7/16" - 11-13/16"	1
GMF4000/NF	3 & 4 Ton	121.2 lbs	3-9/16" - 11-13/16"	1
GMF5000/NF	5 Ton	138.9 lbs	3-9/16" - 11-13/16"	2

*Duty Rating HMI – H4 for all models*

*Visit the Spanco online configurator to verify hoist/trolley compatibility*

## INDUSTRIES SERVED



**MATERIAL HANDLING**



**AUTOMOTIVE**



**RIGGING**



**METAL FABRICATION**



**MUNICIPAL MAINTENANCE**



**CONSTRUCTION**

## MOTORIZED TROLLEY BENEFITS

Workmate motorized trolleys offer one or two speeds of 47 feet per minute maximum. For moving without oscillation and precise positioning of the load, the trolleys can be equipped with frequency inverters. The motorized trolleys are operated, tailored to the respective application, by means of a control switch on the trolley, a control switch independent of the trolley (festoon mounted pendant control box), or radio remote control.



### SUPPORT BOLTS

Galvanized support bolts

- GMF 1250/2500 with 1 support bolt
- GMF 5000 with 2 support bolts

### CROWN LOAD WHEELS

Made of cast iron with ball bearings

Can be used on S & W beams

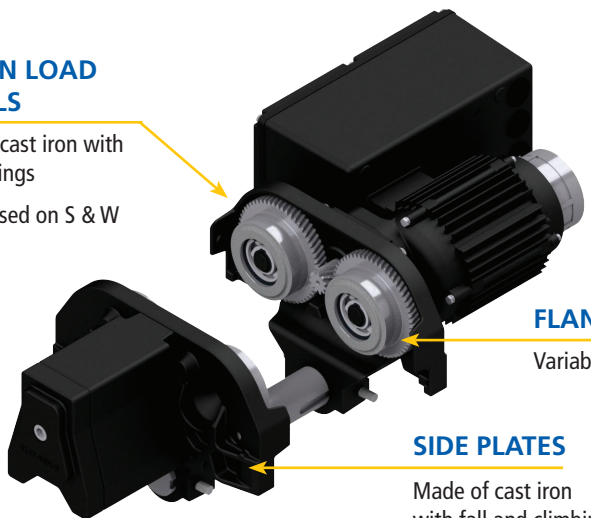

### FLANGE WIDTH

Variable flange width

### SIDE PLATES

Made of cast iron with fall and climbing protection

## SPANCO WARRANTY

### Two-Year Warranty Coverage:

- Defects in equipment material and workmanship of Spanco Workmate electric chain hoists and equipment
- Defects in equipment material and workmanship of motorized systems and equipment
- Paint coatings and finishes in normal operating environments
- Excludes wear items

Spanco warrants motorized equipment to be free from defects in material and workmanship for a period of two (2) years, commencing on the date of shipment to the first retail purchaser. Spanco warrants its paint and finishes for a period of two (2) years. Warranty claims related to coatings must be accompanied by documentation of the product's application and environmental conditions from time of delivery to time of claim.

### Warranty Terms & Conditions:

Spanco terms and conditions can be found on the website at [www.spanco.com](http://www.spanco.com).

